



RT - 1000

 K	118 Kg
	Type SAE.90EP Lt. 12,70

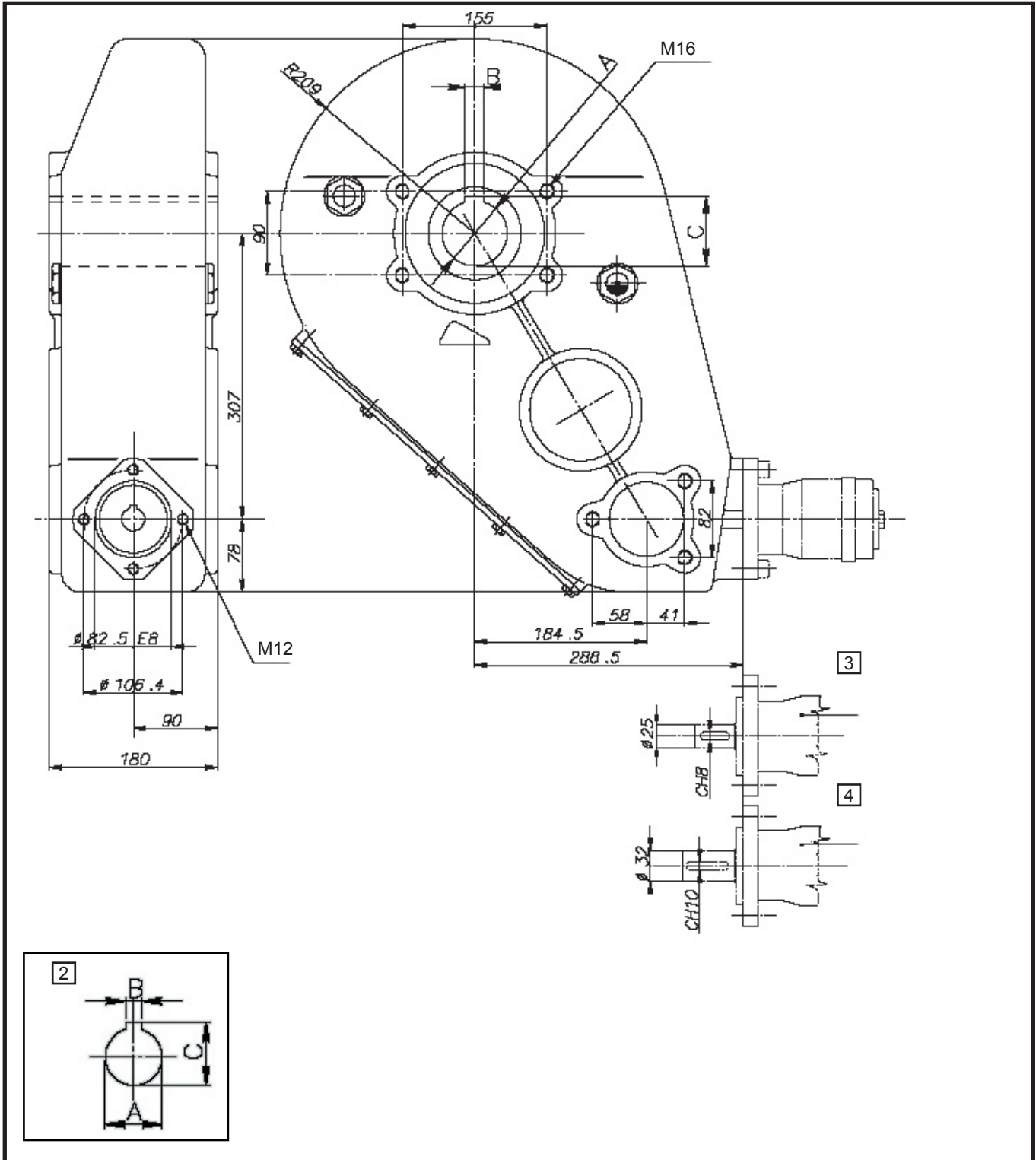

i							
	Nm	A	B	C	D		Ref.
38,7 : 1	9700	60	18	64,4		3	8305306
38,7 : 1	9700	65	18	64,4		3	8305307
38,7 : 1	9700	70	20	74,9		3	8305308
38,7 : 1	9700	60	18	64,4		4	8305309
38,7 : 1	9700	65	18	64,4		4	8305310
38,7 : 1	9700	70	20	74,9		4	8305311

MOTOR	cc				Q	P _{Max}	Ø		
Type			Nm	PK	KW	l/min.	Bar	mm	Ref.
AGMR 50 CD	51,2	770	100	9,4	6,9	40	175	25	8113009
AGMR 80 CD	80,5	745	196	17,1	12,6	60	175	25	8113010
AGMR 100 CD	100,8	600	242	16,3	12	60	175	25	8113011
AGMR 125 CD	125,1	470	271	16,9	12,4	60	175	25	8113012
AGMR 160 CD	159,4	370	389	15,5	11,4	60	175	25	8113013
AGMR 200 CD	199,6	300	450	15,0	11	60	175	25	8113014
AGMR 250 CD	249,8	240	538	14,3	10,5	60	175	25	8113015
AGMR 315 CD	315,7	190	531	12,2	9	60	175	25	8113016
AGMR 400 CD	396,5	150	585	10,5	7,7	60	175	25	8113017
AGMS 80 C	80,8	805	198	22,3	16,4	65	210	32	8113018
AGMS 100 C	99,8	746	244	26,4	19,4	75	210	32	8113019
AGMS 125 C	125,2	598	307	27,2	20	75	210	32	8113020
AGMS 160 C	159,5	465	340	16,3	12	75	210	32	8113021
AGMS 200 C	200	373	395	19,0	14	75	210	32	8113022
AGMS 250 C	252,3	298	450	18,5	13,6	75	210	32	8113023
AGMS 315 C	315,1	236	541	15,6	11,5	75	210	32	8113024
AGMS 400 C	397	187	580	13,6	10	75	210	32	8113025

RFG 12

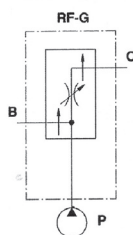
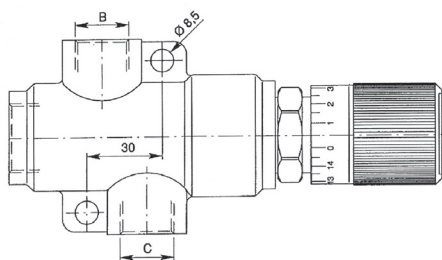

Type	P	B+C	P Max.	Ref.
RFG 12	3/4	1/2	350 Bar	5485015