



RT - 45

 K	11 Kg
	Type SAE.90EP Lt. 0,60

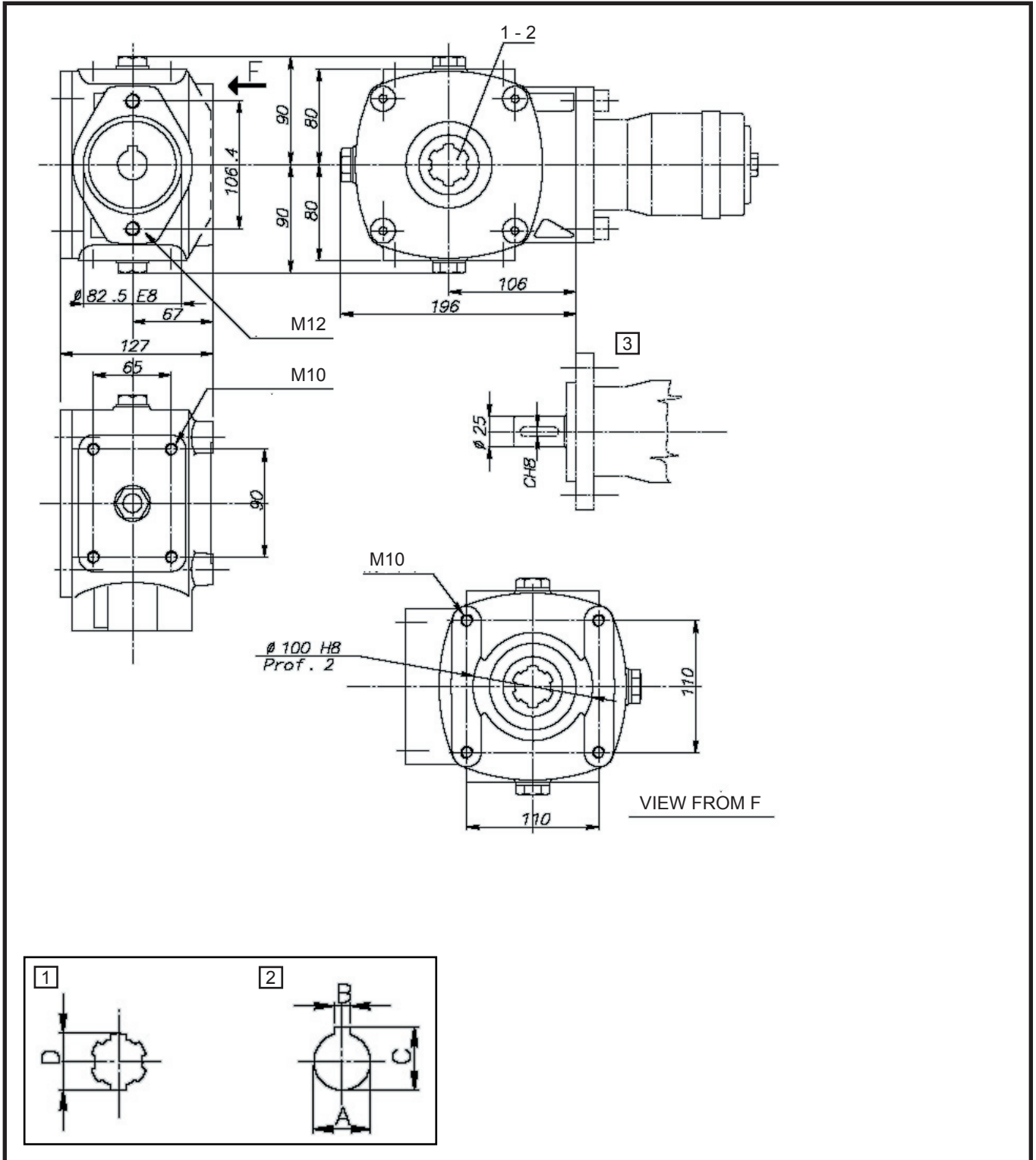

i							
	Nm	A	B	C	D	Ref.	
1,9 : 1	450	30	8	33,8		3	8305301
1,9 : 1	450	35	10	38,8		3	8305302
1,9 : 1	450				1"3/8 (6)	3	8305303

MOTOR	cc				Q	P _{Max}	Ø		
Type			Nm	PK	KW	l/min.	Bar	mm	Ref.
AGMR 50 CD	51,2	770	100	9,4	6,9	40	175	25	8113009
AGMR 80 CD	80,5	745	196	17,1	12,6	60	175	25	8113010
AGMR 100 CD	100,8	600	242	16,3	12	60	175	25	8113011
AGMR 125 CD	125,1	470	271	16,9	12,4	60	175	25	8113012
AGMR 160 CD	159,4	370	389	15,5	11,4	60	175	25	8113013
AGMR 200 CD	199,6	300	450	15,0	11	60	175	25	8113014
AGMR 250 CD	249,8	240	538	14,3	10,5	60	175	25	8113015
AGMR 315 CD	315,7	190	531	12,2	9	60	175	25	8113016
AGMR 400 CD	396,5	150	585	10,5	7,7	60	175	25	8113017

RFG 12

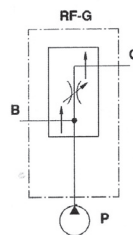
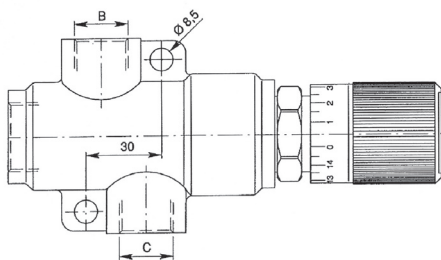

Type	P	B+C	P Max.	Ref.
RFG 12	3/4	1/2	350 Bar	5485015