

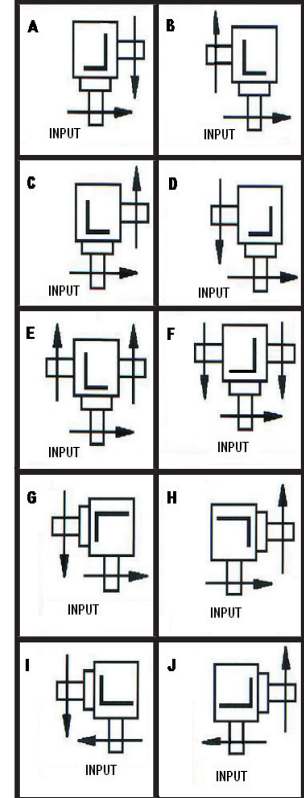

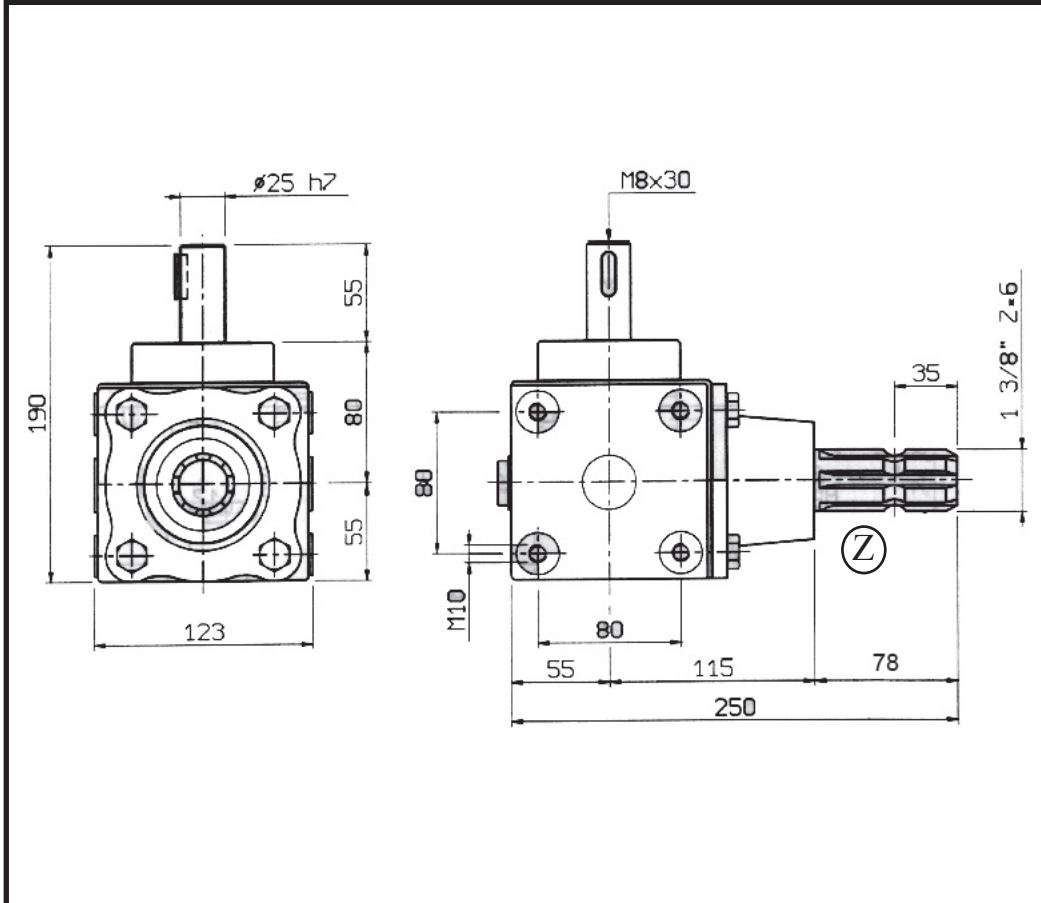

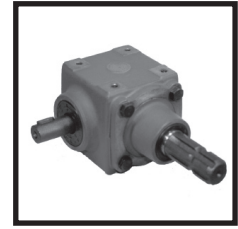

	9 Kg
	Type SAE.90EP Lt. 0,60

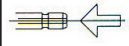

10	Z	11	Z	30	Z	
20	X-Y	21	X-Y	22	X-Y	
			23	X-Y	24	X-Y

i														Ref.
	r.p.m.	r.p.m.	HP	KW	Nm	X	Y	Z						
3.25 : 1	540	166	6	4,5	245	21	21	11	Z	E - F	8305054			
3.25 : 1	540	166	6	4,5	245	21		11	Z	A - B	8305055			
3.25 : 1	540	166	6	4,5	245		21	11	Z	C - D	8305056			
2.78 : 1	540	194	6	4,5	210	21	21	11	Z	E - F	8305051			
2.78 : 1	540	194	6	4,5	210	21		11	Z	A - B	8305052			
2.78 : 1	540	194	6	4,5	210		21	11	Z	C - D	8305053			
1.90 : 1	540	284	9,5	7	240	21	21	10	Z	E - F	8305207			
1.90 : 1	540	284	9,5	7	240	21	21	11	Z	E - F	8305048			
1.90 : 1	540	284	9,5	7	240	21		11	Z	A - B	8305049			
1.90 : 1	540	284	9,5	7	240	21		10	Z	A - B	8305208			
1.90 : 1	540	284	9,5	7	240		21	11	Z	C - D	8305050			
1.35 : 1	540	400	15	11	255	21	21	11	Z	E - F	8305045			
1.35 : 1	540	400	15	11	255	21		11	Z	A - B	8305046			
1.35 : 1	540	400	15	11	255		21	11	Z	C - D	8305047			
1 : 1	540	540	15	11	189	21	21	10	Z	E - F	8305205			
1 : 1	540	540	15	11	189	21	21	11	Z	E - F	8305042			
1 : 1	540	540	15	11	189	21		11	Z	A - B	8305043			
1 : 1	540	540	15	11	189	21		10	Z	A - B	8305206			
1 : 1	540	540	15	11	189		21	11	Z	C - D	8305044			
1 : 1,35	540	729				21		11	X	I - J	8305046			
1 : 1,35	540	729					21	11	Y	G - H	8305047			
1 : 1,90	540	1026				21		11	X	I - J	8305049			
1 : 1,90	540	1026					21	11	Y	G - H	8305050			
1 : 2,78	540	1501				21		11	X	I - J	8305052			
1 : 2,78	540	1501					21	11	Y	G - H	8305053			
1 : 3,25	540	1755				21		11	X	I - J	8305055			
1 : 3,25	540	1755					21	11	Y	G - H	8305056			