

	42 Kg
	Type SAE.90EP Lt. 2,00

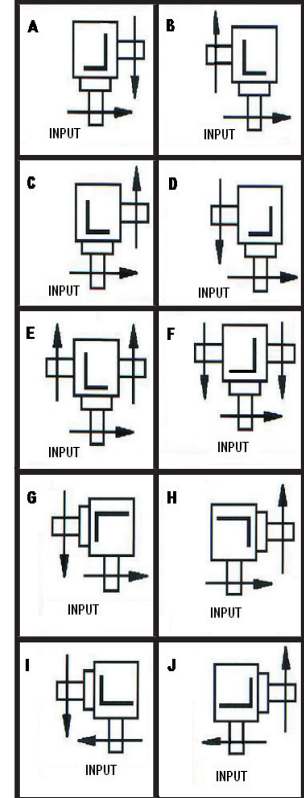
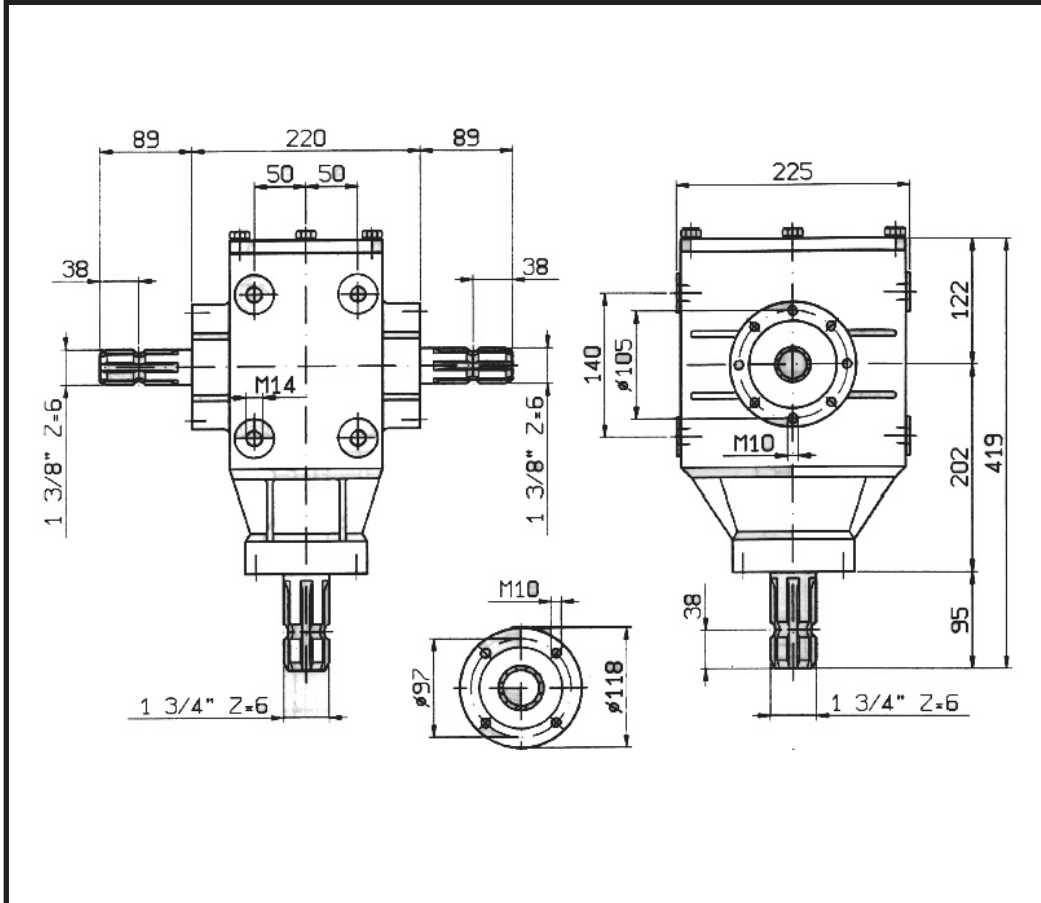
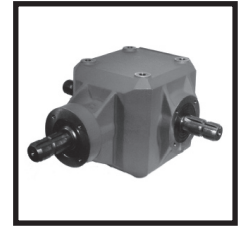

10 Z	11 Z	30 Z	31 Z
20 X-Y	21 X-Y	22 X-Y	23 X-Y

i												Ref.
	r.p.m.	r.p.m.	HP	KW	Nm	X	Y	Z				
4,11 : 1	540	131	25	18	1337	20	20	10	Z	E - F	8305126	
4,11 : 1	540	131	25	18	1337	20		10	Z	A - B	8305127	
4,11 : 1	540	131	25	18	1337		20	10	Z	C - D	8305128	
3,10 : 1	540	174	33	24	1331	20	20	10	Z	E - F	8305123	
3,10 : 1	540	174	33	24	1331	20		10	Z	A - B	8305124	
3,10 : 1	540	174	33	24	1331		20	10	Z	C - D	8305125	
2,58 : 1	540	209	44	32	1477	20	20	10	Z	E - F	8305120	
2,58 : 1	540	209	44	32	1477	20		10	Z	A - B	8305121	
2,58 : 1	540	209	44	32	1477		20	10	Z	C - D	8305122	
1,93 : 1	540	280	50	37	1256	20	20	10	Z	E - F	8305117	
1,93 : 1	540	280	50	37	1256	20		10	Z	A - B	8305118	
1,93 : 1	540	280	50	37	1256		20	10	Z	C - D	8305119	
1,93 : 1	540	1042	82	60	553	20		10	X	I - J	8305118	
1,93 : 1	540	1042	82	60	553		20	10	Y	G - H	8305119	
1 : 2,58	540	1393	82	60	414	20		10	X	I - J	8305121	
1 : 2,58	540	1393	82	60	414		20	10	Y	G - H	8305122	
1 : 3,10	540	1674	73	54	306	20		10	X	I - J	8305124	
1 : 3,10	540	1674	73	54	306		20	10	Y	G - H	8305125	
1 : 4,11	540	2219	61	45	193	20		10	X	I - J	8305127	
1 : 4,11	540	2219	61	45	193		20	10	Y	G - H	8305128	