

HDS 30

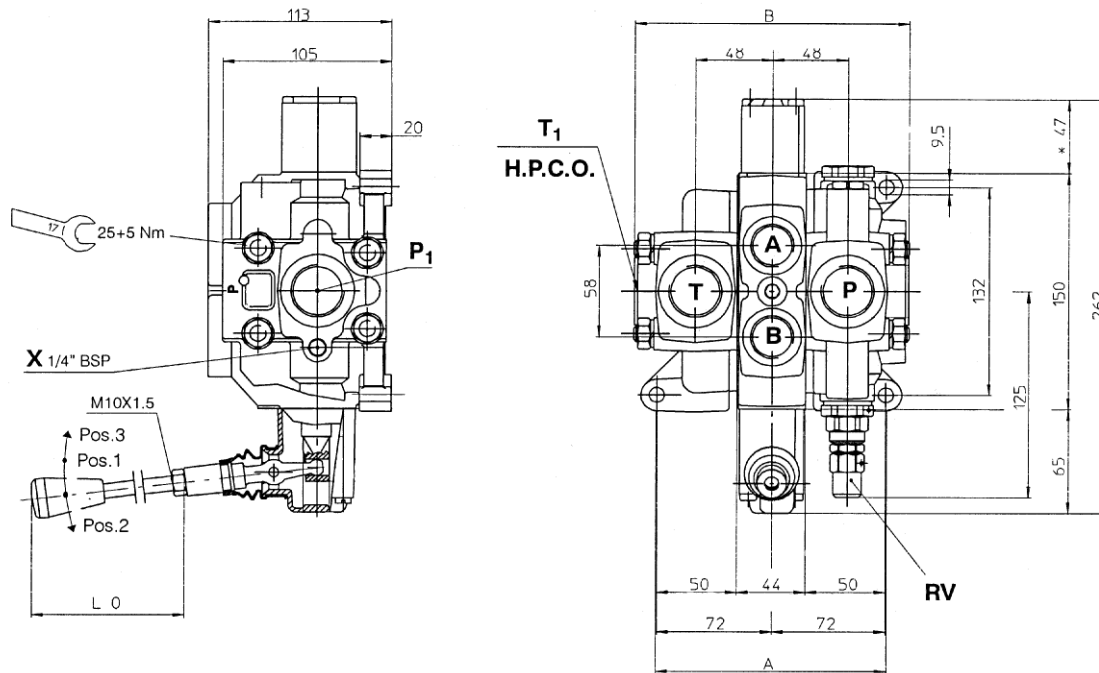



l/min	Druk, bar		Aansluiting BSP	Instelbereik overdrukventiel bar	A		B		Aantal secties
	P,A,B	T			HDS 30/1	Breedte per sectie in mm	HDS 30/1	Breedte per sectie in mm	
120	320	30	P,T 1" A,B 3/4"	30-320	144	44	168	44	1 - 10

HDS 30

Type	Aantal schuiven	Schuifcombinaties				Best. Nr.
		A	C	G	Z	
HDS 30/1 T02 15 P06 K02A01 L100	1	1				*
HDS 30/1 T02 15 P06 K02C01 L100	1		1			*
HDS 30/1 T02 15 P06 K02G01 L100	1			1		*
HDS 30/2 T02 15 P06 K02A01 K02A01 L100	2	2				*
HDS 30/2 T02 15 P06 K02A01 K02 C01 L100	2	1	1			*
HDS 30/2 T02 15 P06 K02A01 K02Z128 L100	2	1			1	*
HDS 30/3 T02 15 P06 K02A01 K02A01 K02A01 L100	3	3				*
HDS 30/3 T02 15 P06 K02A01 K02C01 K02Z128 L100	3	1	1		1	*
HDS 30/3 T02 15 P06 K02A01 K02A01 K02Z128 L100	3	2			1	*

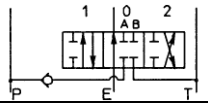
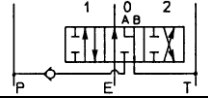
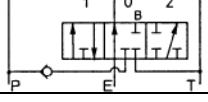
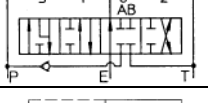
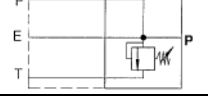
HDS 30 Secties voor samenbouw

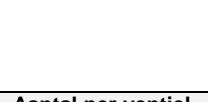
Type	Symbol	Schuiftype	Functie	Best. Nr.
EL HDS 30 K02 A01 L100		A	Dubbelwerkend	8062447
EL. HDS 30 K06 A 01 L100 UC A00/B00		A	Dubbelwerkend met schokventiel	*
EL HDS 30 K02 C133 L100		C	Dubbelwerkend A – B → T	*
EL HDS 30 K02 G01 L100		G	Enkelwerkend	*
EL HDS 30 K02 Z128 L100		Z	Dubbelwerkend met zweefstand	*
HDS 30 T02 15		-	Ingangsplaat met overdrukventiel	8062453
HDS 30 P06		-	Sluitplaat met retour en drukdoorvoer aansluiting. „closed centre“ ook mogelijk.	8062454

HDS 30 Trekbouten

Type	Aantal schuiven	Aantal per ventiel	Best. Nr.
M10 x 173	1	4	*
M10 x 217	2	4	*
M10 x 261	3	4	*
M10 x 305	4	4	*
M10 x 349	5	4	*
M10 x 393	6	4	*
M10 x 437	7	4	*
M10 x 481	8	4	*
M10 x 525	9	4	*
M10 x 569	10	4	*

Hendelstanden voor HDM25, HDS20, HDS30

- x - Neutrale stand
- - Schuif in geblokkeerde stand
- o - Veer terug

Type	Schuifpositie				Best. Nr.
	3	1	0	2	
01		o	x	o	*
02		•	•	o	8069580
03		•	•	•	8069581
05	•	o	x	o	8069583

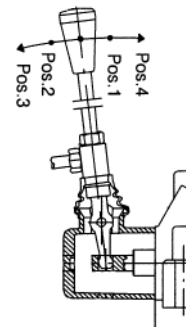

H/P 24, pneumatisch EP 77/78, elektro-pneumatisch

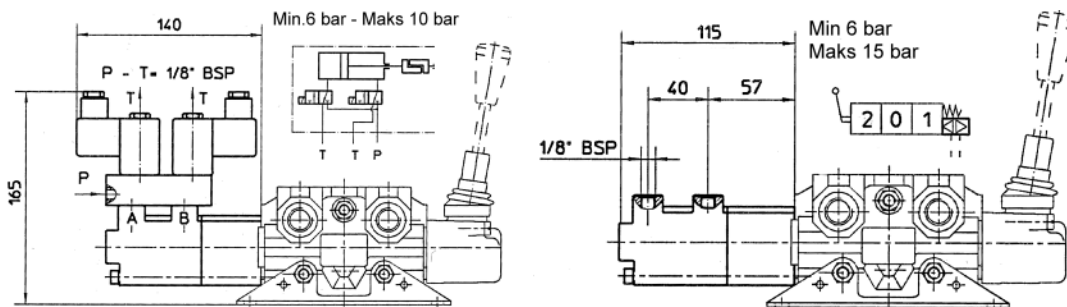

Type	Ventieltype	Schuifafstand mm	Spanning V	Best. Nr.
P/H 24	HDM11S, HDS11	5	-	
P/H 24	HDM18, HDS15	5	-	
P/H 24	HDM25, HDS20, HDS30	7.5	-	8062454
EP77	HDM18, HDS15	5	12	
EP78	HDM18, HDS15	5	24	
EP77	HDM25, HDS20, HDS30	7.5	12	
EP78	HDM20, HDS20, HDS30	7.5	24	

HP 50, hydraulisch-proportioneel

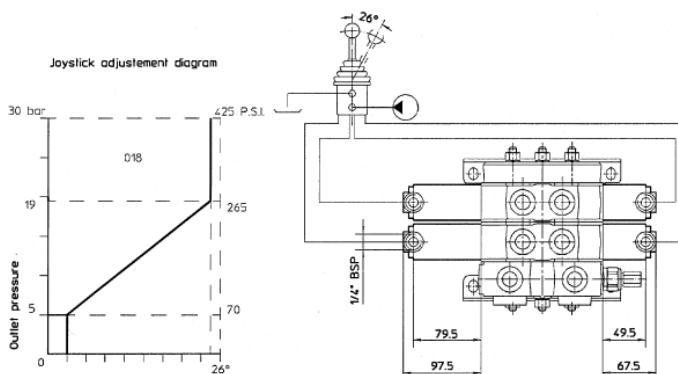

Type	Ventieltype	Schuifafstand mm	Best. Nr.
HP 50	HDM18, HDS15	5	
HP 50	HDM25, HDS20, HDS30	7.5	