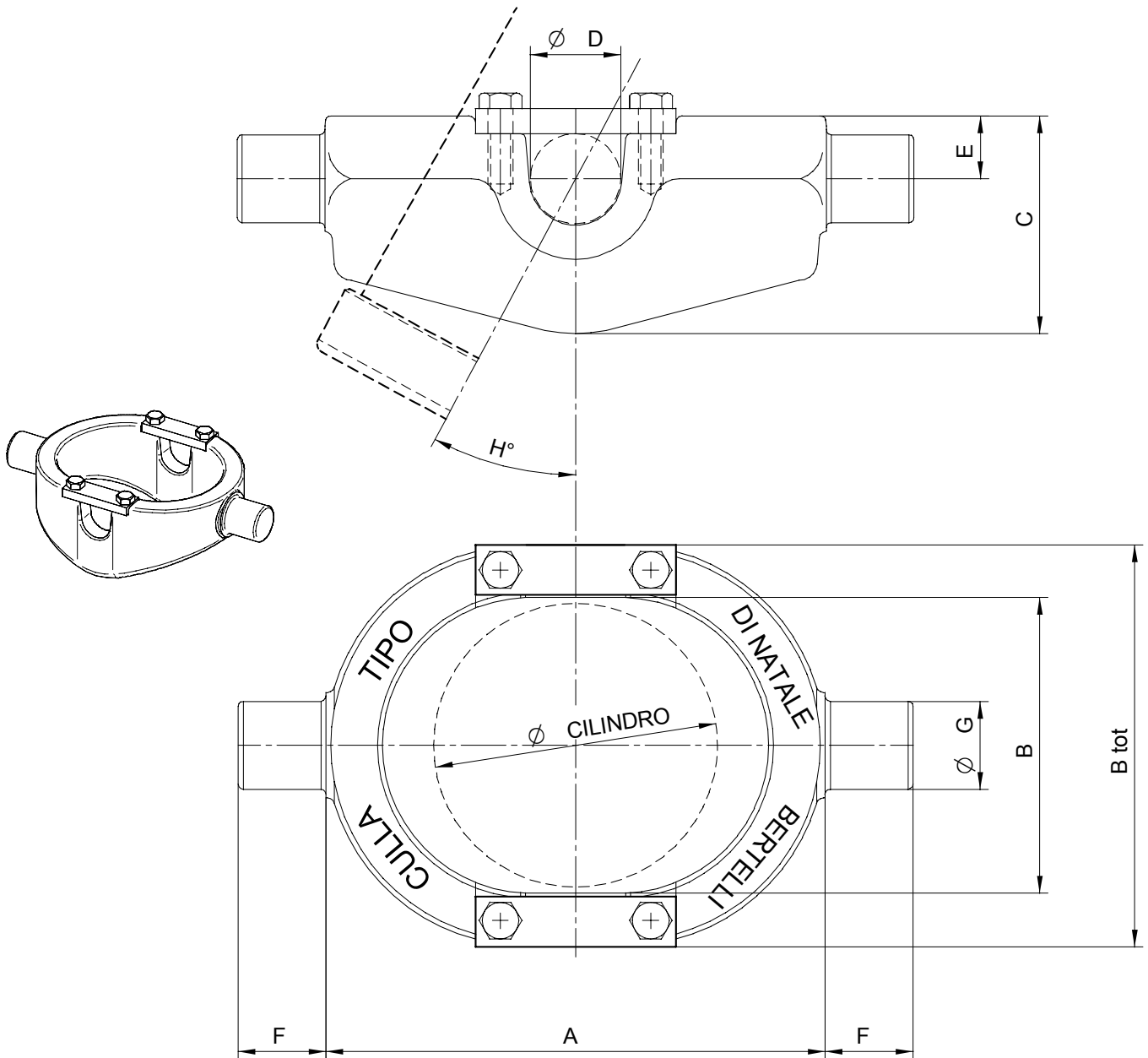

**SCHOMMELS
CRADLES FOR CYLINDERS**
**SUSPENSION À LA CARDAN POUR VERINS
KARDANRING FÜR ZYLINDER**

Materiale: Acciaio stampato UNI Fe 510 - Material: pressed Steel UNI Fe 510 - Materiau: Acier matrice UNI Fe 510 - Werkstoff: Prepstahl UNI Fe 510

TYPE TYPE	AFMETINGEN – DIMENSIONS – DIMENSIONS – ABMESSUNGEN										CHARGE Ton. CAPACITEIT Ton.	POIDS WEIGHT Kg GEWICHT Kg
	A	B	B tot.	C	Ø D	E	F	Ø G	H	Ø Cil.		
CULLA 1	200	120	160	77	35	25	35	35	32°	80/95	7 Ton.	5
CULLA 2	230	135	195	97	35	28	40	40	37°	112	10 Ton.	9
CULLA 3	230	155	215	107	40	31	40	40	30°	124	16 Ton.	10,5
CULLA 4	280	185	240	125	45	40	45	50	30°	150	20 Ton.	15