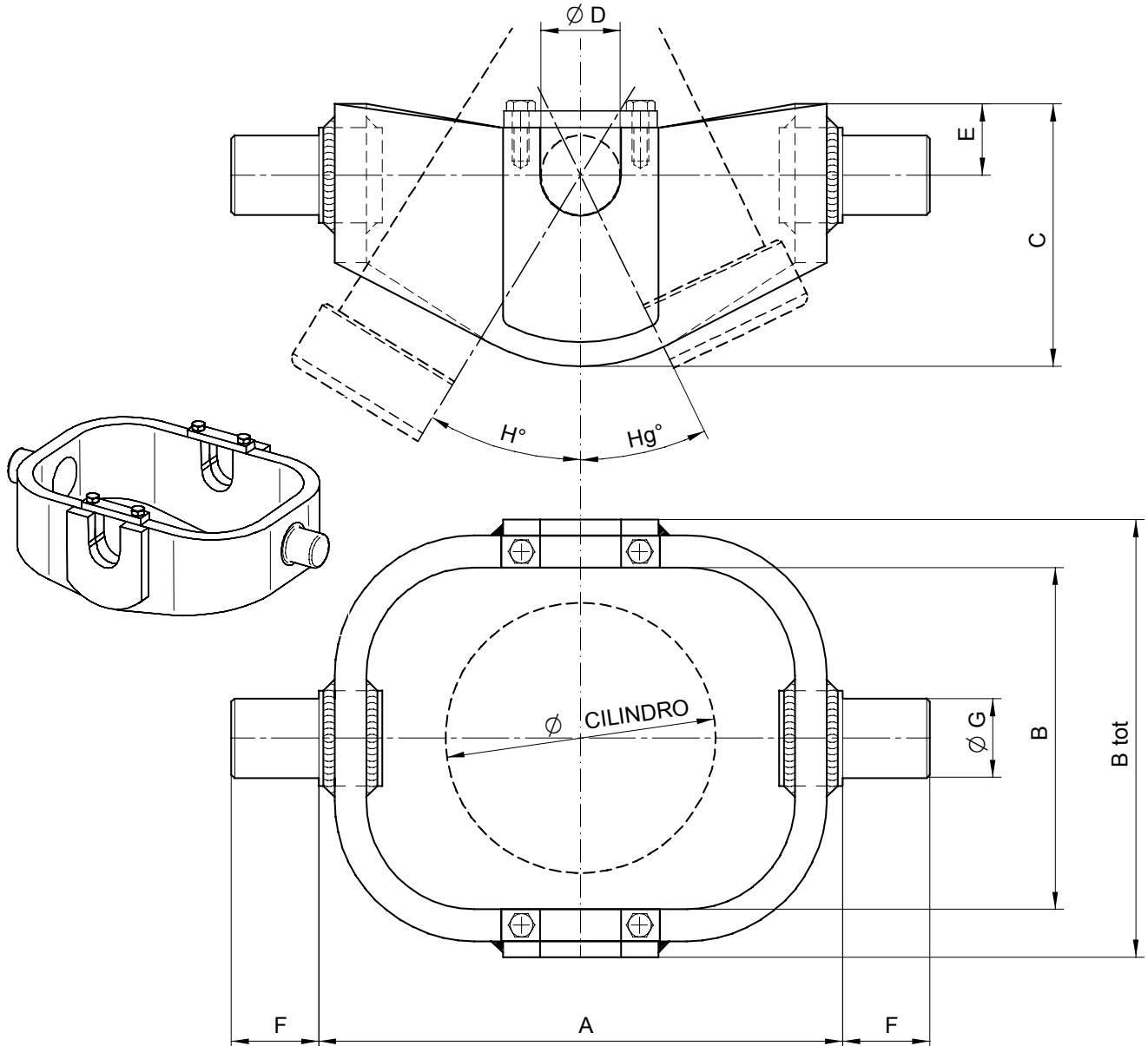

**SCHOMMEL
CRADLES FOR CYLINDERS**
**SUSPENSION À LA CARDAN POUR VERINS
KARDANRING FÜR ZYLINDER**

Materiale: Acciaio Fe 430/C - Material: Steel Fe 430/C - Materiau: Acier Fe 430/C - Werkstoff: Prepstahl Fe 430/C

TYPE TYPE	AFMETINGEN – DIMENSIONS – DIMENSIONS – ABMESSUNGEN											CHARGE Ton. CAPACITY Ton. BELASTBARKEIT Ton.	POIDS WEIGHT Kg GEWICHT Kg
	A	B	B tot	C	Ø D	E	F	Ø G	H°	Hg°	Ø Cil.		
CULLA 5	330	215	290	165	50	45	55	50	30°	26°	170	22 Ton.	22
CULLA 6	390	235	310	205	50	65	55	50	30°	23°	190	23 Ton.	29
CULLA 7	400	255	350	205	50	65	55	50	30°	25°	215	25 Ton.	32
CULLA 8	460	277	370	235	55	68	55	55	34°	27°	240	25 Ton.	52
CULLA 8A	540	277	380	300	70	85	55	70	40°	35°	240	35 Ton.	74
CULLA 9	540	312	395	300	70	85	55	70	36°	30°	270	38 Ton.	77
CULLA 10	540	342	425	300	70	85	55	70	32°	26°	300	38 Ton.	77

Costruite in carpenteria -Fabricated metal structure -Costruites en charpente -Stahlbau