

Leverprogramma agmaster-monoblokventielen

Type	werkdruk Bar	Max. debiet/min	Max. retourdruk Bar	Drukval P - T Bar	max. aantal schuiven
BM 20	300	25	80	5	6
BM 30	250	45	80	6	1
BM 30 Speciaal	250	45	80	6	1
BM 40	320	45	80	5	7
BM 70	300	90	80	6	6
BM 150	300	180	80	4	1
BF 20	320	25	80	6	6
BF 40	320	45	80	6	6
BF 401	300	180	80	6	1
BF 70	300	90	80	3	6

Schuiftype

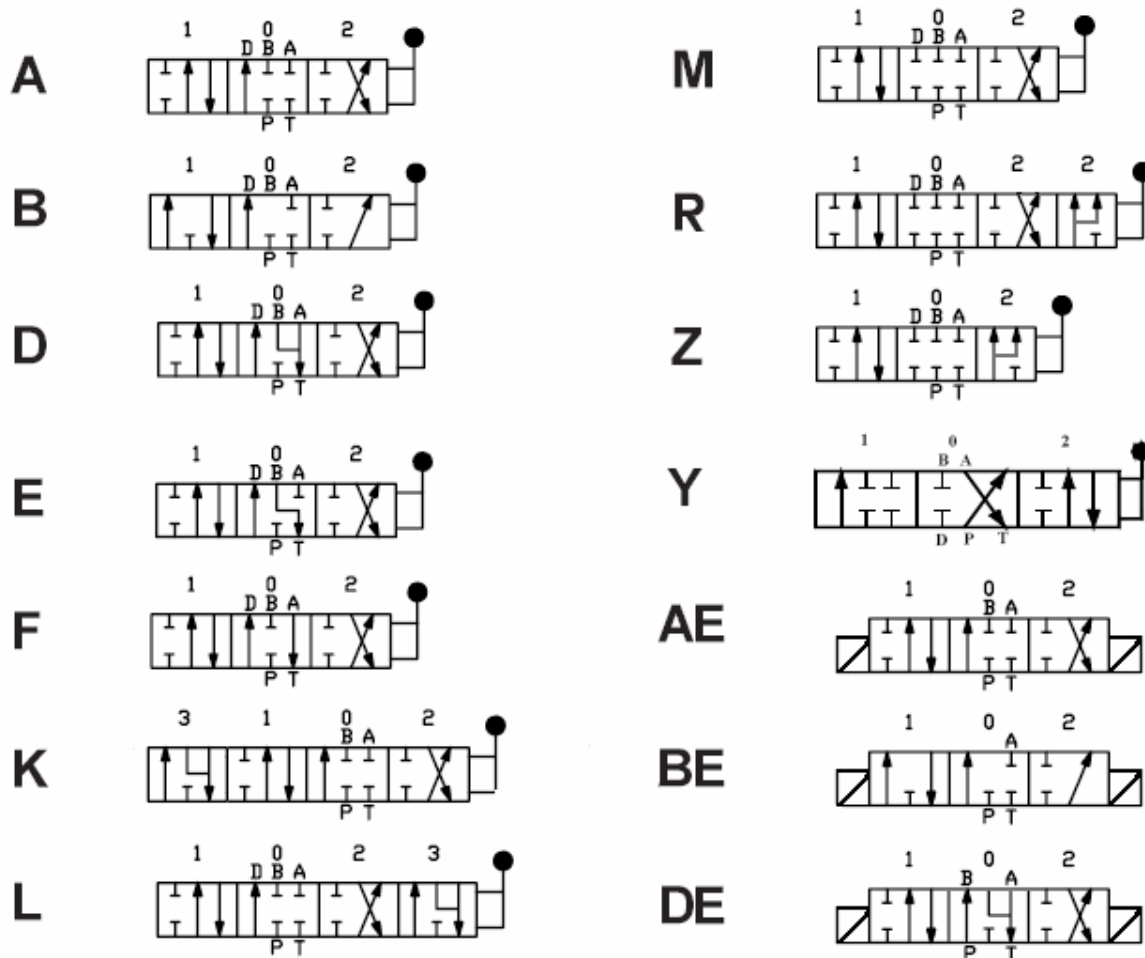

Monoblokventiel BM



Schuiftype Pos. 1	Aantal secties	Schuiftype Pos. 2 - 7	BM 20 Best. Nr.	BM 30 Best. Nr.	BM 30 S Best. Nr.	BM 40 Best. Nr.	BM 70 Best. Nr.	BM 70 S Best. Nr.	BM 100 S Best. Nr.	BM150 Best. Nr.
A	1		8160063	8160000		8160005	8160020			8160045
	2	A	8160066		8160008	8160023				
	2	B	8160067		8160009	8160024				
	2	D	8160068		8160010	8160025				
	3	A-A	8160070		8160012	8160027				
	3	A-B	8160071		8160013	8160028				
	3	A-D	8160072		8160014	8160029				
4	A-A-A	8160073	8160015	8160030						
5	A-A-A-A	8160075	8160017	8160032						
6	A-A-A-A-A	8160076	8160018	8160033						
7	A-A-A-A-A-A		8160019							
B	1		8160064	8160001		8160006	8160021			8160046
	2	B	8160069		8160011	8160026				
D	1			8160002		810007	8160022			8160047
	2									
	3									
	4	D-D-D	8160074		8160016	8160031				
ZI	1				8160003			81600XX	81600XX	

Monoblokventiel BF

De stuurventielen in de BF series zijn met een prioriteitsventiel en debietregelaar uitgerust.

Schuiftype Pos. 1	Aantal secties	Schuiftype. 2 - 7	BF 20 Best. Nr.	BF 40 Best. Nr.	BF 401 Best. Nr.	BF 70 Best. Nr.	BF 701 Best. Nr.
A	1		8160034	8160037		8160040	
B	1		8160035	8160038		8160041	
D	1		8160036	8160039			
Y	1				8160078		8160081

Monoblokventiel BM 20

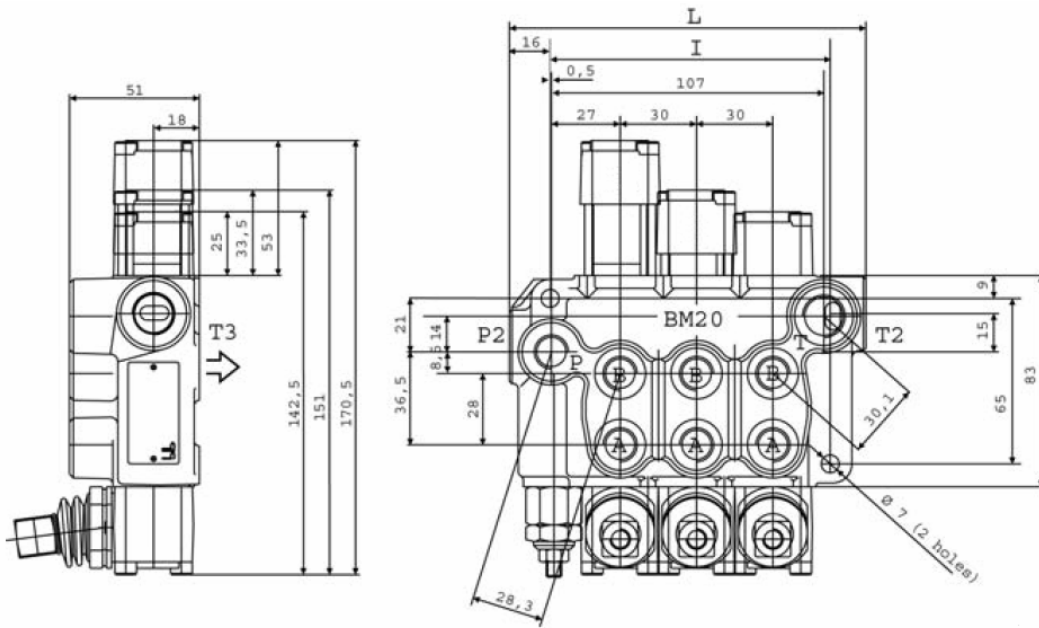

Block	L	I
BM 20/1	76	50
BM 20/2	106	80
BM 20/3	136	110
BM 20/4	166	140
BM 20/5	196	170
BM 20/6	226	200

l/min	Druk, bar		Aansluiting, BSP		Instelbereik Overdrukventiel bar	Aantal secties
	A, B, P	T	A, B, P	T, P2, T2		
25	320	80	1/4"	3/8"	10-90 70/140 Standaard 100-250	1 - 6

Monoblokventiel BM 30

BM 30/L = LEFT INLET (A-B-C)

BM 30/L = RIGHT INLET (A-B-C-D)

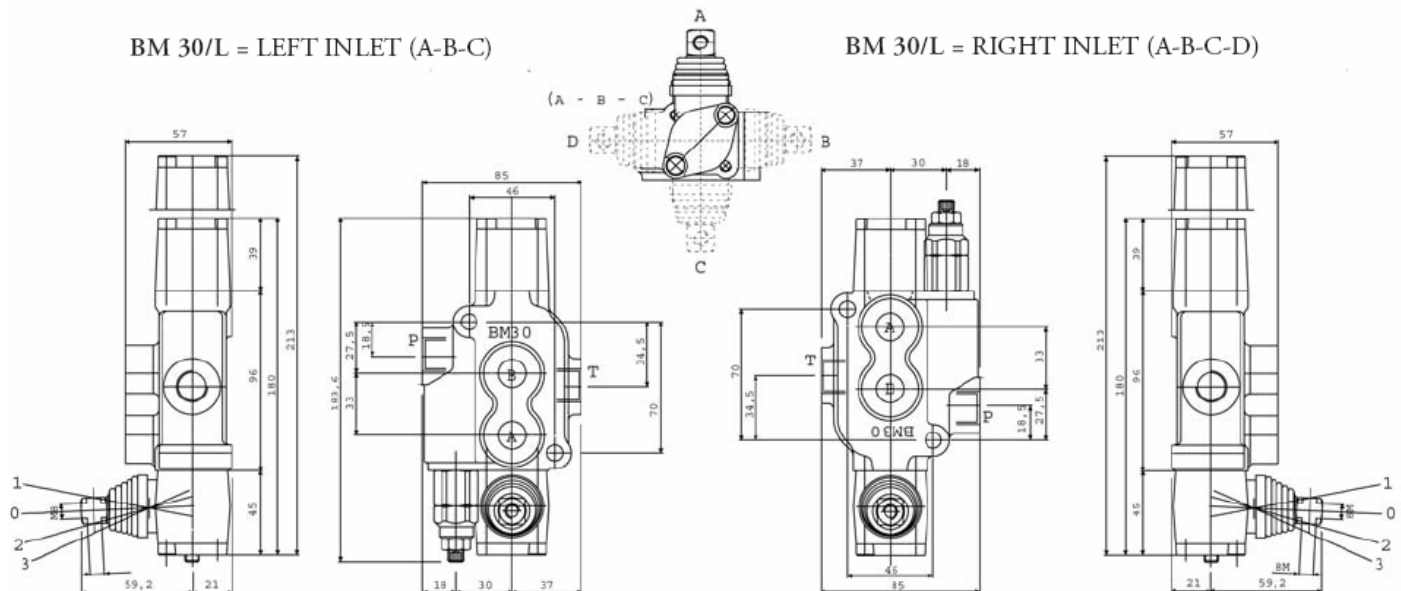

l/min	Druk, bar		Aansluiting, BSP		Instelbereik Overdrukventiel bar	Aantal secties
	A, B, P	T	A, B, P	P2, T2		
45	320	80	3/8"	3/8"	10-90 70/140 Standaard 100-250	1

Monoblokventiel BM 40

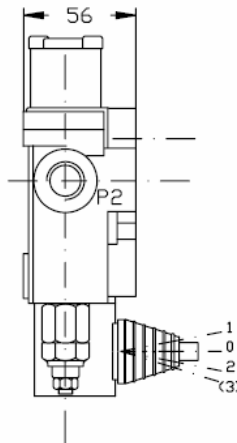
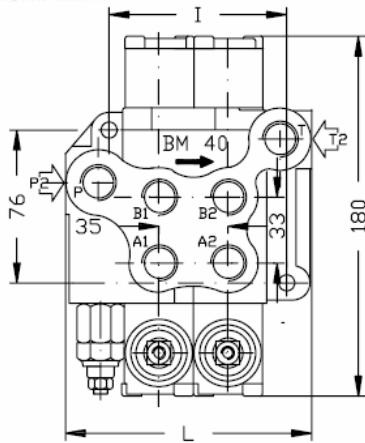

Block	L	I
BM 40/1	90	55
BM 40/2	125	90
BM 40/3	160	125
BM 40/4	195	160
BM 40/5	230	195
BM 40/6	285	230

l/min	Druk, bar		Aansluiting, BSP		Instelbereik Overdrukventiel bar	Aantal secties
	A, B, P	T	A, B, P, T	P2, T2		
45	320	80	3/8"	1/2"	10-90 70/140 Standaard 100-250	1 - 7

Monoblokventiel BM 70

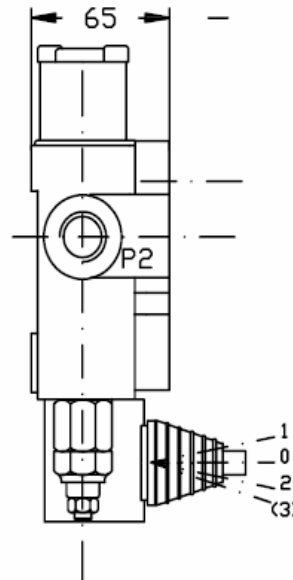
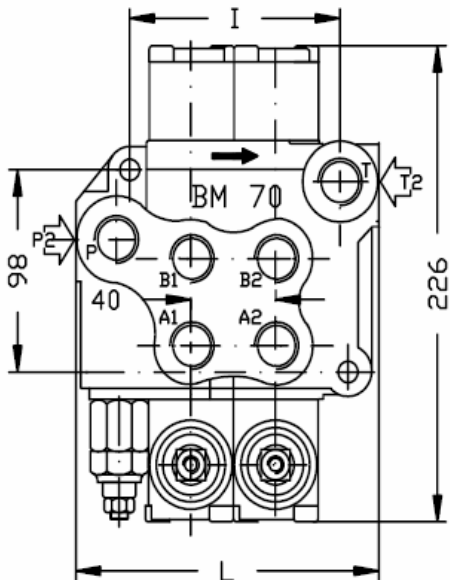

Block	L	I
B M 70/1	117	66
B M 70/2	157	106
B M 70/3	197	146
B M 70/4	237	186
B M 70/5	277	226
B M 70/6	317	266

l/min	Druk, bar		Aansluiting, BSP		Instelbereik Overdrukventiel bar	Aantal secties
	A, B, P	T	A, B, P, T	P2, T2		
90	320	80	1/2"	3/4"	10-90 70/140 Standaard 150-300 100-250	1 - 6

Monoblokventiel BM 150

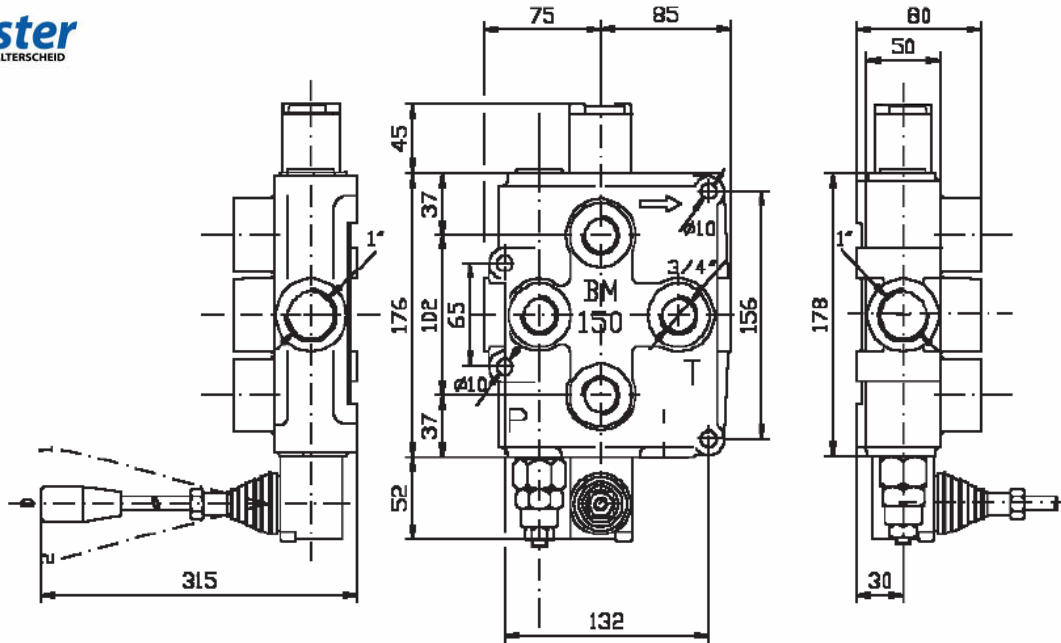

l/min	Druk, bar		Aansluiting, BSP		Instelbereik Overdrukventiel bar	Aantal secties
	A, B, P	T	A, B, P, T	P2, T2		
180	320	80	3/4"	1"	10-90 70/140 Standaard 100-250	1

Monoblokventiel BM 30 S/BM 70 S/BM 100 S "Houtklierventiel"



l/min	Druk, bar		Aansluiting, BSP		Instelbereik Overdrukventiel bar	Aantal secties
	A, B, P	T	A, B, P	P2, T2		
45	250	80	3/8"	3/8"	10-90 70/140 Standaard 100-250	1
90	250	80	1/2"	3/4"	10-90 70/140 Standaard 100-250	1
100	250	80	3/4"	3/4"	10-90 70/140 Standaard 100-250	1

Monoblokventil BF 20

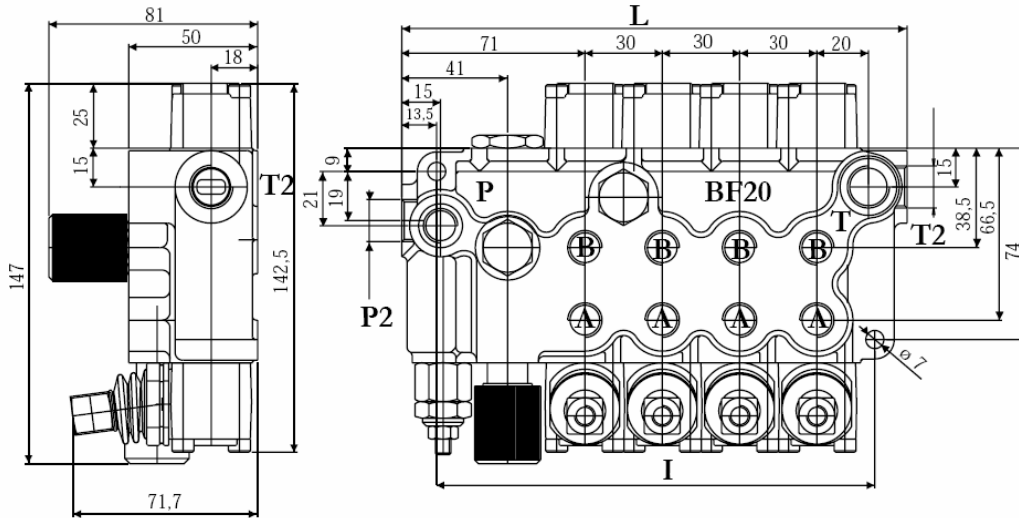

Ausführungen:

- 1 Mengenregler stirnseitig
- 2 ... Mengenregler anschlussseitig

Block	L	I
BF 20/1	76	50
BF 20/2	106	80
BF 20/3	136	110
BF 20/4	166	140
BF 20/5	196	170

l/min	Druk, bar		Aansluiting, BSP		Instelbereik Overdrukventiel bar	Aantal secties
	A, B, P	T	A, B, P, T	P2, T2		
25	320	80	3/4"	1"	10-90 70/140 Standaard 100-250	6

Monoblokventiel BF 40

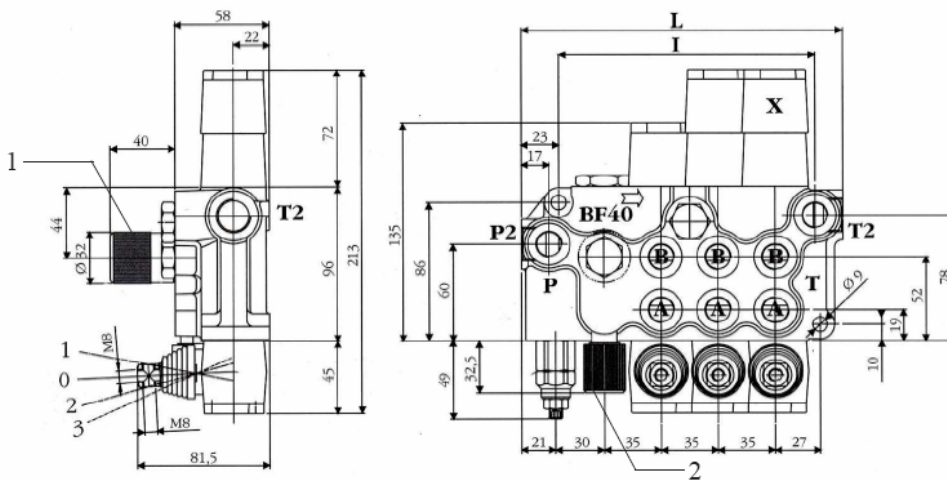

Ausführungen:

- 1 Mengenregler stirnseitig
- 2 ... Mengenregler anschlussseitig

Block	L	I
BF 40/1	125	90
BF 40/2	160	125
BF 40/3	195	160
BF 40/4	230	195
BF 40/5	265	230
BF 40/6	300	265

l/min	Druk, bar		Aansluiting, BSP		Instelbereik Overdrukventiel bar	Aantal secties
	A, B, P	T	A, B, P, T	P2, T2		
45	320	80	3/8"	1/2"	10-90 70/140 Standaard 100-250	6

Monoblokventiel BF 401



l/min	Druk, bar		Aansluiting, BSP		Instelbereik Overdrukventiel bar	Aantal secties
	A, B, P	T	A, B, P, T	P2, T2		
180	320	80	3/4"	1"	10-90 70/140 Standard 100-250	1

Monoblokventiel BF 70

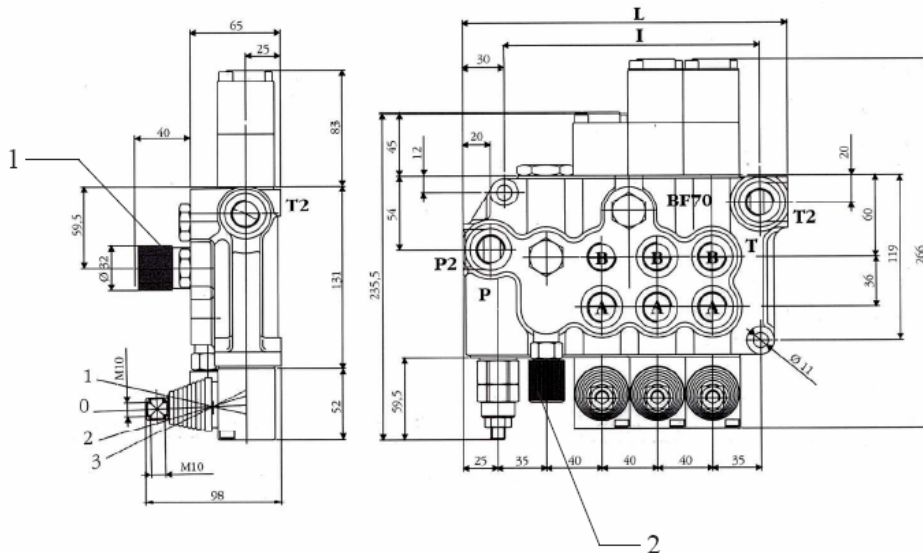

Ausführungen:

- 1 ... Mengenregler stirnseitig
- 2 ... Mengenregler anschlussseitig

Block	L	I
BF 70/1	157	106
BF 70/2	197	146
BF 70/3	237	186
BF 70/4	277	226
BF 70/5	317	266

l/min	Druk, bar		Aansluiting, BSP		Instelbereik Overdrukventiel bar	Aantal secties
	A, B, P	T	A, B, P, T	P2, T2		
90	320	80	1/2"	3/4"	10-90 70/140 Standaard 100-250	6

Monoblokventiel BF 701



l/min	Druk, bar		Aansluiting, BSP		Instelbereik Overdrukventiel bar	Aantal secties
	A, B, P	T	A, B, P, T	P2, T2		
45	300	80	1/2"	3/4"	10-90 70/140 Standard 100-250	1