

Dubbelwerkende balanceerklep Valves d'équilibrage double

Materiaal / Matière: Staal / Acier

Max. druk / pression max.: 250 BAR

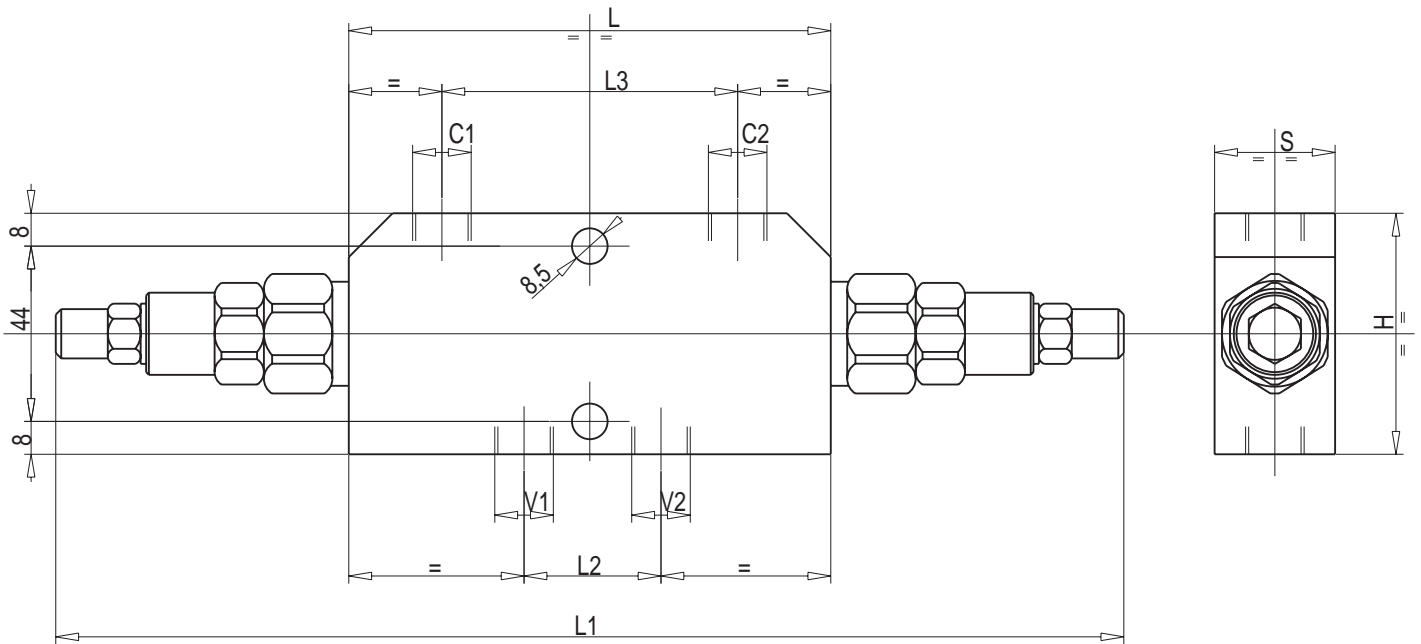

Hydraulisch Schema Schéma hydraulique

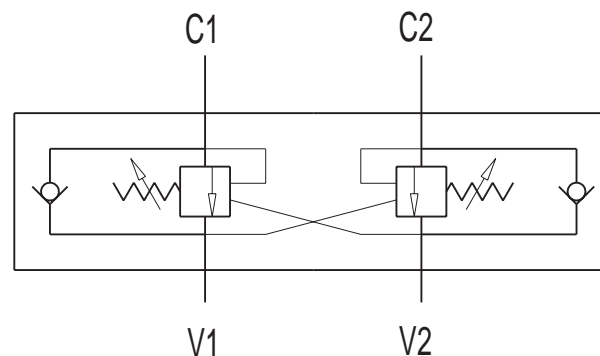

Bestelnr. Référence	TYPE	Stuurdrukverhouding Rapport de pilotage	Max. debiet / débit	V1-V2 C1-C2	L	L1	L2	L3	H	S
			Lt./min.	BSP						
8070011	VBCD 3/8 D.E.	1 : 3,1	35	G3/8	120	264	34	73	60	30
8070012	VBCD 1/2 D.E.	1 : 3,1	50	G1/2	120	264	36	73	60	30
8070013	VBCD 3/4 D.E.	1 : 5,5	105	G 3/4	152	296	58	106	80	35